

Eaton 93PX 15 – 20 kVA UPS

EATON

Powering Business Worldwide

The new Eaton 93PX 15 - 20 kVA UPS provides stable power for critical IT infrastructure, industrial, manufacturing and medical devices. With its advanced technology to improve the double conversion efficiency and reduce footprint, it saves both energy and rack space. Eaton 93PX UPS has robustness in design for harsh environments or applications outside of a comms room.

IT infrastructure
(High-density Racks)



Industrial &
Manufacturing



Medical
Applications



Key Features

High power density

- The 15 kVA / 20 kVA power module uses only 3U rack space.
- Short depth chassis suitable to be deployed in cabinets as shallow as 800 mm deep.
- 438 mm width for standard 19" rack mounting.



93PX reduces space with same power rating.

Unity power factor

Eaton 93PX UPS powers more servers than similar UPSs with equivalent kVA ratings with lower power factors.

Unity power factor $kVA = kW$

Versatile installation

Eaton 93PX UPS can easily be deployed as a rack mount or free standing (tower) unit.

Versatile wiring

- Wide array of connection options.
- Input and output wiring can be connected as 3 phase or 1 phase.
- 3-3, 3-1, 1-1 mode
- Utility input and bypass input can be connected as single source or dual source.
- All wiring modes catered for by a single SKU. The configuration is done during installation.



Cybersecurity

Cybersecurity is at the core of our “secure by design” philosophy and is embedded in all Eaton’s Intelligent Power products and platforms that we bring to market.

An Eaton secure-by-design solution



Complies with rigorous cybersecurity, process, requirements and testing standards

Eaton Cyber Secured Monitoring

Eaton Cyber Secured Monitoring is the right solution to connect your device without any compromise to security and availability. It runs on a secured cloud and allows enabling services such as Health Reports and early anomaly detection that help to mitigate downtime risk associated with the critical components (battery, capacitors, fans etc.).

Eaton Deliverables	Benefits
24/7 monitoring by EATON specialist team*	Faster response to malfunctions reducing delay related to travel to site
UPS remote monitoring portal including real-time UPS diagnostics to evaluate situation before travelling to site	Minimized risk related to power interruption due to reduced MTTR and increased first time fix rate
Early anomalies notification enabled by alarms management system managed by EATON service expert team	Improved reliability performance by addressing early signs of degradation
Comprehensive monthly Health report of UPS performance and EATON recommendations	Proactive maintenance investment optimization to execute only the tasks that are needed

*24/7 monitoring is only available with Remote Monitoring

Parallel operation

For redundancy and expanded power rating.

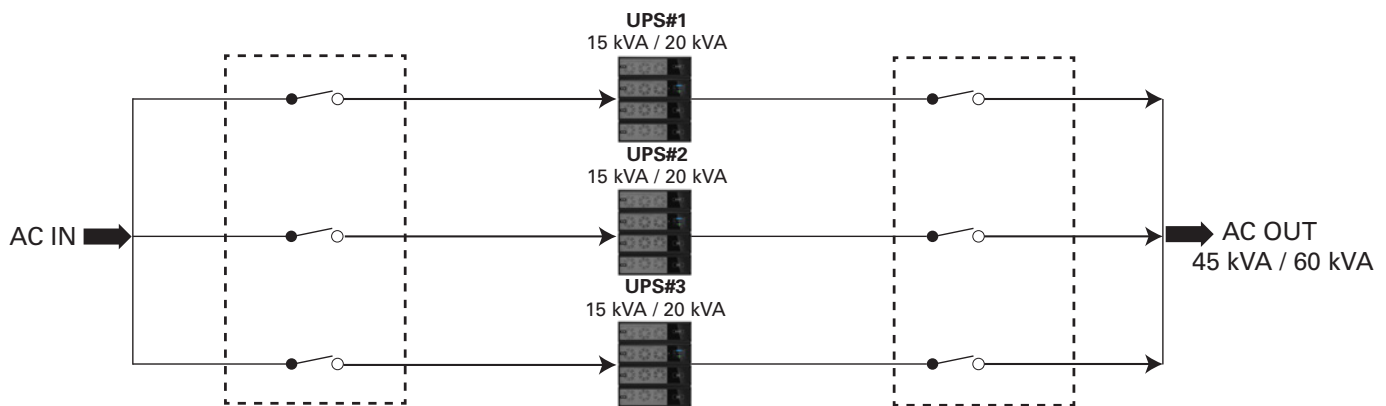

Maximum parallel 3 models

Total Cost of Ownership (TCO)

Eaton 93PX UPS helps you to save more than 850 € annually in operating expenses with its outstanding efficiency. You can also double your savings up to 10 000 € in 5 years by utilizing ESS mode.

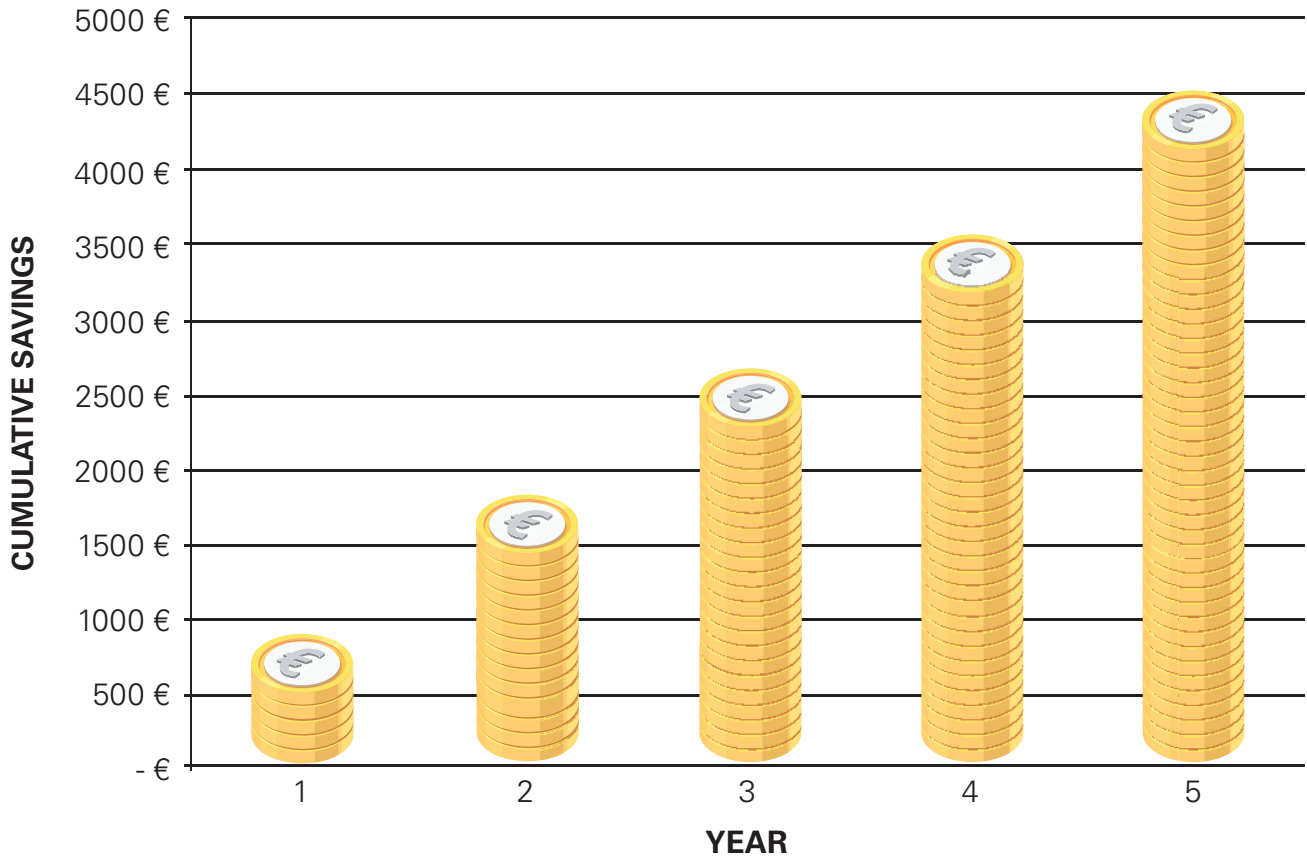

Data used for calculation

- Eaton 93PX vs. 94 % efficiency UPS
- Electricity price 0,1833 €/kWh (Euro area average)
- Cooling ratio 20 %, 20 kW load
- Savings/year in online mode 851,33 €
- Savings/year in ESS mode 1988,98 €

More than
DOUBLE YOUR SAVINGS by utilizing
ESS MODE

10 000 €
/ 5 years

ESS mode

Achieve up to **98.8 % efficiency** in ESS mode. System switches to online mode on demand in less than 2 ms response time.

High efficiency

Double conversion efficiency of Eaton 93PX UPS is **96 %**.

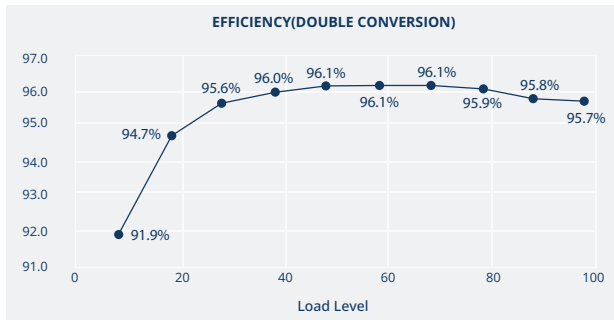

Eaton 93PX UPS reduces energy usage and CO₂ emissions to help IT Managers save costs on power and cooling.

Battery Management

Eaton's exclusive ABM[®] technology increases battery service life by 50 %. ABM uses an advanced, three-stage charging technique and closely monitors battery health to provide advanced notice when batteries need replacement. Variable charging current ranges from 0-13 A, suitable for recharging larger battery banks.

Professional HMI for operation, configuration and setting

Multi connectivity port – RS232, USB, dry in/out, EPO, intelligent slot.

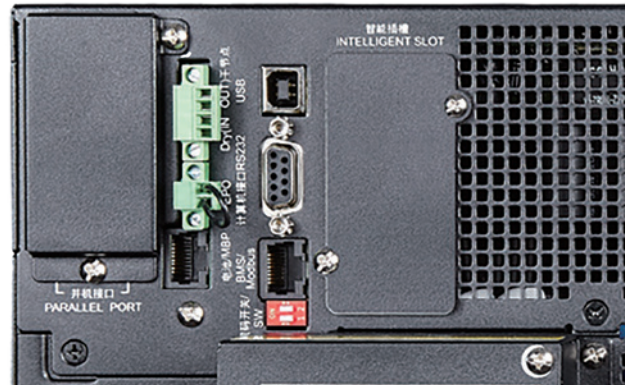

Large coloured touch screen LCD

Built-in gravity sensor that automatically rotates the screen based on UPS deployment orientation.



Intelligent Power Manager

IPP/IPM compatible with all major OS including virtualization software such as VMware and Hyper-V.

Endure harsh environment



Operation
temperature
up to 50 °C.



Maximum operation
altitude up to
4000 m.



Line mode overload
capacity up to
10 min at 125 %
rated load.

Product accessories

MBP (Maintenance bypass model)



Integrated maintenance bypass and load segment. Load segment control enables prioritized shutdown of nonessential equipment to maximize battery runtime for critical devices.



Paralleling module available for ease of deployment of a 2 UPS paralleled system.

EBM

Connect up to 6 pairs (2*6) of EBMs for extended runtime.



Minimum deployment is 2 x EBMs per UPS, with increments of 2s.

Connectivity cards

Network-M2



Eaton Gigabit Network Card

INDGW-M2



Eaton Gigabit Modbus Card

EMPDT1H1C2



Environmental Monitoring Probe
Monitors temperature and humidity.

Technical specifications

UPS power module	93PX 15 kVA	93PX 20 kVA
Input		
Rated input voltage	1 phase 220/230/240 V; 3 phase 380/400/415 V	
Input voltage range	160 V ~ 300 V full load; 100 ~ 160 V linear derating	
Rated input frequency	50 Hz / 60 Hz	
Input frequency range	40 Hz - 70 Hz	
Input frequency phase lock range	50 Hz system: 45 Hz - 55 Hz 60 Hz system: 54 Hz - 66 Hz	
System compatibility	TN-S / IT	
Input power factor (PF)	> 0.995 both 1 phase and 3 phases	
THDi	≤ 3 % linear load; ≤ 5 % non-linear load	
Output		
Input-output phase connection	Input-output 3-1, 3-3, 1-1	
Rated output voltage	1 phase 220/230/240 V; 3 phase 380/400/415 V	
Rated output frequency	50 Hz / 60 Hz	
Rated output appearance power	15 kVA	20 kVA
Rated output active power	15 kW	20 kW
Max PF	1	
Voltage variation	± 1 %	
THDV	≤ 1 % linear load; ≤ 3 % non-linear load	
Load crest ratio	≥ 3:1	
Output connection	Terminal block	
Overload capacity line mode (at rated voltage)	105 % < Load ≤ 125 % : 10 min 125 % < Load ≤ 150 % : 1 min > 150 % : 0.5 s	
Battery and charger		
Internal batteries	None. 1 pair of EBMs as minimum to provide backup time	
Max. quantity	6 pairs (2*6)	
Battery voltage	± 240 V (adjustable to ± 192 V for external battery solutions)	
Charging current	0 ~ 13 A adjust	
Recharging time	3 hours to 90 % (2 EBM)	
Efficiency		
Online mode	up to 96 %	
ECO or ESS mode	up to 98.8 %	
Other working mode		
Parallel mode	Maximum 3 (60 kVA/kW)	
Interface		
Display	Coloured touch LCD with gravity sensor	
Connectivity port	RS232 DB9; USB 2.0 type-B; programmable dry contacts in/out; 1 x Mini-Slot for comms cards	

Technical specifications

UPS power module	93PX 15 kVA	93PX 20 kVA
Physical dimension		
Dimension (H*W*D)	129 mm * 438 mm * 589 mm	
Net weight (Kg)	23.7	
Environment		
Operation temperature	0 °C ~ 50 °C (0 ~ 40 no derating, 40 °C ~ 50 °C derating to 50 %)	
Storage temperature	- 25 °C ~ 60°C	
Relative humidity	0 ~ 95 %	
Operating altitude	0 ~ 4000 m (0 ~ 1000 m no derating, 1000 m ~ 4000 m the load derating 1 % every up 100 m)	
Noise level	≤ 55 dB	
EBM (External Battery Module)		
Dimension (H*W*D)	129 mm * 438 mm * 589 mm	
Net weight (Kg)	124.2	
MBP (Maintenance Bypass)		
Dimension (H*W*D)	129 mm * 438 mm * 489 mm	
Net weight (Kg)	21.5	

Part number

Model	93PX 15 kVA	93PX 20 kVA
Product description	Part number	
UPS power module	93PX15KiPM	93PX20KiPM
External battery module 480 V	93PXEBM480 (contains 2 x (240 V, 3RU) modules each)	
MBP	MBP20Ki	
MBP with power distribution	MBP20KiPDU	
MBP parallel 2 x 20 kW	MBP20KiPARA	
Network card	Network-M2	
Modbus card	INDGW-M2	
Environmental monitoring probe	EMPDT1H1C2	
Netpack 9U (includes power module, EBM, rack kit and network card)	93PX15KIRTN	93PX20KIRTN

Backup time table

EBM quantity	Load	Backup time (Min) - 15 kVA	Backup time (Min) - 20 kVA
1 group (2*240 V EBM)	100 %	3.8	2.4
	75 %	5.7	3.8
	50 %	9.5	9.6
	25 %	23.5	24.9
2 group (2*2*240 V EBM)	100 %	13.8	8.5
	75 %	20.7	13.8
	50 %	35.1	25.4
	25 %	91.0	65.6
3 group (3*2*240 V EBM)	100 %	26.3	17.0
	75 %	39.4	26.3
	50 %	68.1	42.9
	25 %	179.3	98.7
4 group (4*2*240 V EBM)	100 %	39.8	25.1
	75 %	59.6	39.8
	50 %	104.3	67.2
	25 %	277.8	133.0



At your service everywhere

With three Power Quality manufacturing facilities in the EMEA region, plus a strong local service presence, Eaton will provide your UPS with expert support from day one to the end of its service life.

At Eaton, we like to keep things simple. So, we have compiled service plans to match different types of maintenance needs and budgets. Whichever plan you choose, you can rest assured it will deliver power security and reliability that will keep your business running.